



Indigo 150 LED

ORDERCODE 41379



SHOWELECTRONICS FOR PROFESSIONALS

Congratulations!

You have bought a great, innovative product from Showtec.

The Showtec Indigo 150 LED brings excitement to any venue. Whether you want simple plug-&-play action or a sophisticated DMX show, this product provides the effect you need.

You can rely on Showtec, for more excellent lighting products.

We design and manufacture professional light equipment for the entertainment industry.

New products are being launched regularly. We work hard to keep you, our customer, satisfied.

For more information: iwant@showtec.info

You can get some of the best quality, best priced products on the market from Showtec.

So next time, turn to Showtec for more great lighting equipment.

Always get the best -- with Showtec !

Thank you!



Warning..... 2
Safety-instructions..... 2
Operating Determinations..... 4
Rigging..... 4
Return Procedure..... 5
Claims..... 5

Description..... 6
Features and Overview 6
Backside..... 7

Installation..... 7

Set Up and Operation..... 7
Control Modes..... 7
 One Indigo (Built-in Programs)..... 7
 One Indigo (Sound Control)..... 7
 Multiple Indigo's (Master/Slave control)..... 8
 Multiple Indigo's (DMX control)..... 8
Fixture Linking..... 9
Data Cabling..... 9
Control Panel..... 10
Control Mode..... 10
DMX addressing..... 10
MENU OVERVIEW 11
 Main Menu Options..... 12
 1. Intro..... 12
 DMX Addressing..... 12
 Reset..... 12
 DMX Active..... 12
 Built-in Programs Mode..... 13
 Built-in Programs (Auto_1 + Auto_2) 13
 Sound-controlled (Sound_1 + Sound_2) 13
 Custom Mode..... 13
 Run Test..... 13
 Slave Mode..... 13
 Channels Advanced/Basic Mode..... 14
 Display Mode..... 14
 Info version..... 14
 2. Invert..... 14
 3. Range..... 15
 4. Special..... 15
 5. Edit..... 16
 6. Default..... 16
 DMX Channels..... 17
 12 Channels (ADVANCED) 17
 9 Channels (BASIC)..... 19
 Channel settings..... 21

Beam Angle..... 21

Maintenance..... 21
Replacing the Fuse..... 22
Replacing a Gobo from the Rotating Gobo-wheel 22
Gobo Orientation..... 23
Colorwheel and Rotating Gobowheel..... 23

Troubleshooting..... 23
No Light, No Movement - All Products..... 23
No Response to DMX 24

Product Specifications..... 25

WARNING

**FOR YOUR OWN SAFETY, PLEASE READ THIS USER MANUAL CAREFULLY
BEFORE YOUR INITIAL START-UP!**

Unpacking Instructions

Immediately upon receiving this product, carefully unpack the carton and check the contents to ensure that all parts are present, and have been received in good condition. Notify the dealer immediately and retain packing material for inspection if any parts appear damaged from shipping or the carton itself shows signs of mishandling. Save the carton and all packing materials. In the event that a fixture must be returned to the factory, it is important that the fixture be returned in the original factory box and packing.

Your shipment includes:

- Showtec Indigo 150 LED with powercable 1,75m
- 2 brackets for truss mounting
- User manual



LED Expected Lifespan



LEDs gradually decline in brightness over time. HEAT is the dominant factor that leads to the acceleration of this decline. Packaged in clusters, LEDs exhibit higher operating temperatures than in ideal or singular optimum conditions. For this reason when all color LEDs are used at their fullest intensity, life of the LEDs is significantly reduced. It is estimated that a viable lifespan of 40,000 to 50,000 hours will be achieved under normal operational conditions. If improving on this lifespan expectancy is of a higher priority, place care in providing for lower operational temperatures. This may include climatic-environmental and the reduction of overall projection intensity.

 **CAUTION!** 
**Keep this device away from rain and moisture!
Unplug mains lead before opening the housing!**

SAFETY INSTRUCTIONS

Every person involved with the installation, operation and maintenance of this device has to:

- be qualified
- follow the instructions of this manual

 **CAUTION! Be careful with your operations.
With a dangerous voltage you can suffer
a dangerous electric shock when touching the wires!** 

Before your initial start-up, please make sure that there is no damage caused by transportation. Should there be any, consult your dealer and do not use the device.

To maintain perfect condition and to ensure a safe operation, it is absolutely necessary for the user to follow the safety instructions and warning notes written in this manual.

Please consider that damages caused by manual modifications to the device are not subject to warranty.

This device contains no user-serviceable parts. Refer servicing to qualified technicians only.

IMPORTANT:

The manufacturer will not accept liability for any resulting damages caused by the non-observance of this manual or any unauthorized modification to the device.

- Never let the power-cord come into contact with other cables! Handle the power-cord and all connections with the mains with particular caution!
- Never remove warning or informative labels from the unit.
- Never use anything to cover the ground contact.
- Never lift the fixture by holding it at the projector-head, as the mechanics may be damaged. Always hold the fixture at the transport handles.
- Never place any material over the lens.
- Never look directly into the light source.
- Never leave any cables lying around.
- Never unscrew the screws of the rotating gobo, as the ball bearing will otherwise be opened.
- Do not insert objects into air vents.
- Do not connect this device to a dimmerpack.
- Do not switch the device on and off in short intervals, as this would reduce the device's life.
- Do not touch the device's housing bare-handed during its operation (housing becomes very hot). Allow the fixture to cool for at least 5 minutes before handling.
- Do not shake the device. Avoid brute force when installing or operating the device.
- Only use device indoor, avoid contact with water or other liquids.
- Only operate the fixture after having checked that the housing is firmly closed and all screws are tightly fastened.
- Only operate the device after having familiarized with its functions.
- Avoid flames and do not put close to flammable liquids or gases.
- Always keep case closed while operating.
- Always allow free air space of at least 50 cm around the unit for ventilation.
- Always disconnect power from the mains, when device is not used or before cleaning! Only handle the power-cord by the plug. Never pull out the plug by tugging the power-cord.
- Make sure that the device is not exposed to extreme heat, moisture or dust.
- Make sure that the available voltage is not higher than stated on the rear panel.
- Make sure that the power-cord is never crimped or damaged. Check the device and the power-cord from time to time.
- If the lens is obviously damaged, it has to be replaced. So that its functions are not impaired, due to cracks or deep scratches.
- If device is dropped or struck, disconnect mains power supply immediately. Have a qualified engineer inspect for safety before operating.
- If the device has been exposed to drastic temperature fluctuation (e.g. after transportation), do not switch it on immediately. The arising condensation water might damage your device. Leave the device switched off until it has reached room temperature.
- If your Showtec device fails to work properly, discontinue use immediately. Pack the unit securely (preferably in the original packing material), and return it to your Showtec dealer for service.
- For adult use only. Movinghead must be installed out of the reach of children. Never leave the unit running unattended.
- Never attempt to bypass the thermostatic switch or fuses.
- For replacement use fuses of same type and rating only.
- The user is responsible for correct positioning and operating of the Indigo. The manufacturer will not accept liability for damages caused by the misuse or incorrect installation of this device.
- This device falls under protection class I. Therefore it is essential to connect the yellow/green conductor to earth.
- During the initial start-up some smoke or smell may arise. This is a normal process and does not necessarily mean that the device is defective.
- Repairs, servicing and electric connection must be carried out by a qualified technician.
- WARRANTY: Till one year after date of purchase.



CAUTION ! EYEDAMAGES !
Avoid looking directly into the light source.
(meant especially for epileptics) !



OPERATING DETERMINATIONS

- This device is not designed for permanent operation. Consistent operation breaks will ensure that the device will serve you for a long time without defects.
- The minimum distance between light-output and the illuminated surface must be more than 1 meter.
- The maximum ambient temperature $t_a = 45^\circ\text{C}$ must never be exceeded.
- If this device is operated in any other way, than the one described in this manual, the product may suffer damages and the warranty becomes void.
- Any other operation may lead to dangers like short-circuit, burns, electric shock, lamp explosion, crash etc.

You endanger your own safety and the safety of others!

Rigging

Please follow the European and national guidelines concerning rigging, trussing and all other safety issues.

Do not attempt the installation yourself !

Always let the installation be carried out by an authorized dealer !

Procedure:

- If the projector is lowered from the ceiling or high joists, professional trussing systems have to be used.
- Use a clamp to mount the projector, with the mounting-bracket, to the trussing system.
- The projector must never be fixed swinging freely in the room.
- The installation must always be secured with a safety attachment, e.g. an appropriate safety net or safety-cable.
- When rigging, derigging or servicing the projector, always make sure, that the area below the installation place is blocked and staying in the area is forbidden.

The Indigo can be placed on a flat stage floor or mounted to any kind of truss by a clamp.

Mounting a clamp to the underside of the Indigo moving head

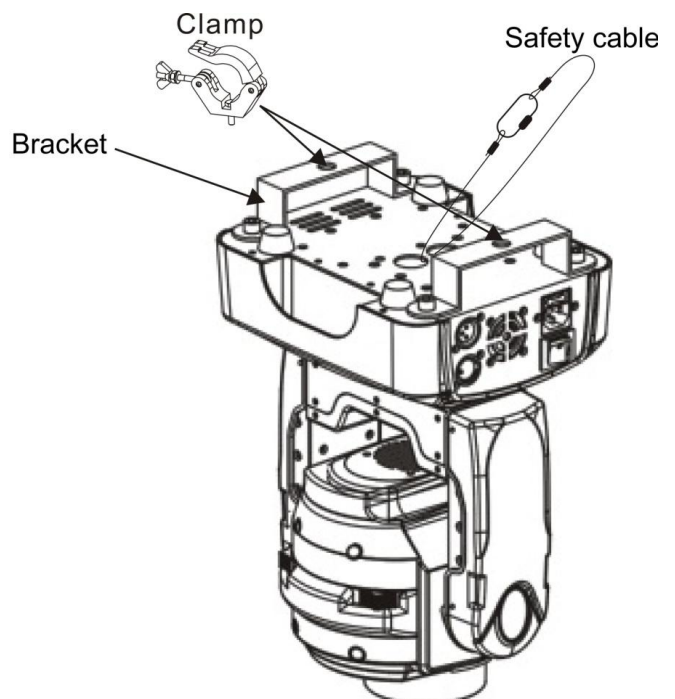

Improper installation can cause serious damage to people and property !

Connection with the mains

Connect the device to the mains with the power-plug.

Always pay attention, that the right color cable is connected to the right place.

International	EU Cable	UK Cable	US Cable	Pin
L	BROWN	RED	YELLOW/COPPER	FASE
N	BLUE	BLACK	SILVER	NUL
	YELLOW/GREEN	GREEN	GREEN	EARTH

Make sure that the device is always connected properly to the earth!



Return Procedure

Returned merchandise must be sent prepaid and in the original packing, call tags will not be issued. Package must be clearly labeled with a Return Authorization Number (RMA number). Products returned without an RMA number will be refused. Highlite will not accept the returned goods or any responsibility. Call Highlite 0031-455667723 or mail aftersales@highlite.nl and request an RMA prior to shipping the fixture. Be prepared to provide the model number, serial number and a brief description of the cause for the return. Be sure to properly pack fixture, any shipping damage resulting from inadequate packaging is the customer's responsibility. Highlite reserves the right to use its own discretion to repair or replace product(s). As a suggestion, proper UPS packing or double-boxing is always a safe method to use.

Note: If you are given an RMA number, please include the following information on a piece of paper inside the box:

- 1) Your name
- 2) Your address
- 3) Your phone number
- 4) A brief description of the symptoms

Claims

The client has the obligation to check the delivered goods immediately upon delivery for any shortcomings and/or visible defects, or perform this check after our announcement that the goods are at their disposal. Damage incurred in shipping is the responsibility of the shipper; therefore the damage must be reported to the carrier upon receipt of merchandise.

It is the customer's responsibility to notify and submit claims with the shipper in the event that a fixture is damaged due to shipping. Transportation damage has to be reported to us within one day after receipt of the delivery.

Any return shipment has to be made post-paid at all times. Return shipments must be accompanied with a letter defining the reason for return shipment. Non-prepaid return shipments will be refused, unless otherwise agreed in writing.

Complaints against us must be made known in writing or by fax within 10 working days after receipt of the invoice. After this period complaints will not be handled anymore.

Complaints will only then be considered if the client has so far complied with all parts of the agreement, regardless of the agreement of which the obligation is resulting.

Description of the device

Features

The Showtec Indigo 150 LED is a moving-head with high output and great effects.

- Compact and attractive design
- Low power consumption
- Sharp optics
- DMX-control via standard DMX-controller
- Music Control
- Automatic Pan/Tilt correction
- Gobowheel with 7 rotating gobos and open
- Interchangeable Gobosystem
- Gobo Shake Function
- Colourwheel with 9 vivid colours and white
- Manual Focus
- Built-in Automatic Programs/ Built-in Sound activated programs
- 3 facet prism
- Power Consumption: 20W
- Cooling system: Low Noise Fan
- Beam Angle: 16 degrees
- Shutter: 0-10Hz
- Dimmer: 0-100% electronic dimmer
- Pan 0° -- 530°
- Tilt 0° -- 270°
- Control: DMX-512, Master/Slave, Sound
- Basic (9CH) or Advanced (12CH) operating modes
- Lux: 588 at 1m
- User selectable pan/tilt ranges
- 3 pin XLR Male and Female connectors
- Bright LCD display
- Mounting System: 2 brackets
- Fuse T1,5A / 250V

Overview



Fig. 1

- 1) Lens
- 2) Menu Buttons + LCD Display

Backside



Fig. 2

- 3) IEC power connector + Fuse 1,5A 250V
- 4) On/Off
- 5) DMX signal connector (IN) 3-pin
- 6) DMX signal connector (OUT) 3-pin

Installation

Remove all packing materials from the Indigo 150 LED. Check that all foam and plastic padding is removed. Connect all cables.

Do not supply power before the whole system is set up and connected properly.

Always disconnect from electric mains power supply before cleaning or servicing.

Damages caused by non-observance are not subject to warranty.

Set Up and Operation

Follow the directions below, as they pertain to your preferred operation mode.

Before plugging the unit in, always make sure that the power supply matches the product specification voltage. Do not attempt to operate a 120V specification product on 230V power, or vice versa.

Connect the device to the main power supply. The device can be music-controlled by its built-in microphone.

Control Modes

There are 4 modes:

- Stand-alone (built-in programs)
- Sound-controlled
- Master/Slave
- DMX512 (12 Channels ADVANCED or 9 channel BASIC)

One Indigo (Built-in Programs)

1. Fasten the effect light onto firm trussing. Leave at least 0,5 meter on all sides for air circulation.
2. When the Indigo is not connected by a DMX-cable, it functions as a stand-alone device.
Please see page 14 for more information about the built-in programs.

One Indigo (Sound-control)

1. Plug the end of the electric mains power cord into a proper electric power supply socket.
2. Turn on the music. If the device is set to sound-control, then the Indigo will react to the beat of the music. Please see page 14 for more information about the sound-control options.

Multiple Indigo's (Master/Slave control)

1. Fasten the effect light onto firm trussing. Leave at least 0,5 meter on all sides for air circulation.
2. Use a 3-p XLR cable to connect the Indigo.



1. Earth
2. Signal -
3. Signal +

3. Link the units as shown in (Fig. 3), Connect a DMX signal cable from the first unit's DMX "out" socket to the second unit's "in" socket. Repeat this process to link the second, third, and fourth units. You can use the same functions on the master device as described on page 14 (Built-in Programs, or Music control). This means on the master device you can set your desired operation Mode and all slave devices will react the same as the master device.

Multiple Indigo's (Master/Slave control)



Fig. 3

Multiple Indigo's (DMX Control)

1. Fasten the effect light onto firm trussing Leave at least 1 meter on all sides for air circulation.
2. Always use a safety cable.
3. Use a 3-p XLR cable to connect the Indigo's and other devices.

Occupation of the XLR-connection:

DMX-OUTPUT XLR mounting-socket:



- 1 - Ground
- 2 - Signal (-)
- 3 - Signal (+)

DMX-input XLR mounting-plug

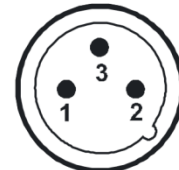

- 1 - Ground
- 2 - Signal (-)
- 3 - Signal (+)

The transformation of the controller line of 3 pins and 5 pins (plug and socket)

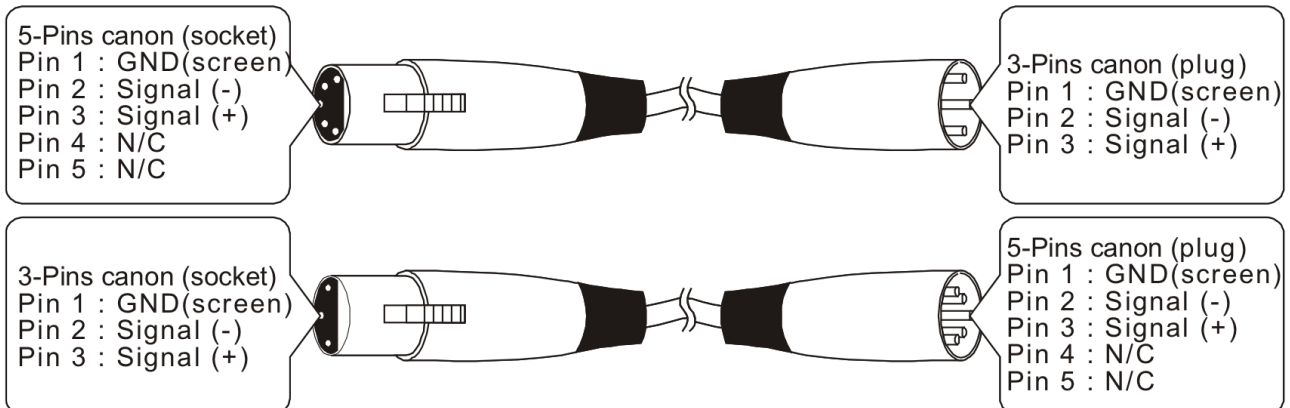

4. Link the units as shown in (figure 4), Connect a DMX signal cable from the first unit's DMX "out" socket to the second unit's "in" socket. Repeat this process to link the second, third, and fourth units.
5. Supply electric power: Plug electric mains power cords into each unit's IEC socket, then plug the other end of the mains power cord into proper electric power supply sockets, starting with the first unit. Do not supply power before the whole system is set up and connected properly.

Multiple Indigo's DMX Set Up



Note : Link all cables before connecting electric power

Fixture Linking

You will need a serial data link to run light shows of one or more fixtures using a DMX-512 controller or to run synchronized shows on two or more fixtures set to a master/slave operating mode. The combined number of channels required by all the fixtures on a serial data link determines the number of fixtures the data link can support.

Important: Fixtures on a serial data link must be daisy chained in one single line. To comply with the EIA-485 standard no more than 30 devices should be connected on one data link. Connecting more than 30 fixtures on one serial data link without the use of a DMX optically isolated splitter may result in deterioration of the digital DMX signal.



Maximum recommended DMX data link distance: 100 meters
 Maximum recommended number of Indigo's on a DMX data link: 30 fixtures

Data Cabling

To link fixtures together you must obtain data cables. You can purchase DAP Audio certified DMX cables directly from a dealer/distributor or construct your own cable. If you choose to create your own cable please use data-grade cables that can carry a high quality signal and are less prone to electromagnetic interference.

DAP Audio Certified DMX Data Cables

- DAP Audio cable for allround use. bal. XLR/M 3 p. > XLR/F 3 p.
Ordercode FL01150 (1,5m.), FL013 (3m.), FL016 (6m.), FL0110 (10m.), FL0115 (15m.), FL0120 (20m.).
- DAP Audio cable for the demanding user with exceptional audio-qualities and connector made by Neutrik®. **Ordercode** FL71150 (1,5m.), FL713 (3m.), FL716 (6m.), FL7110 (10m.).

The Indigo 150 LED can be operated with a controller in **control mode** or without the controller in **stand-alone mode**.

Control Panel

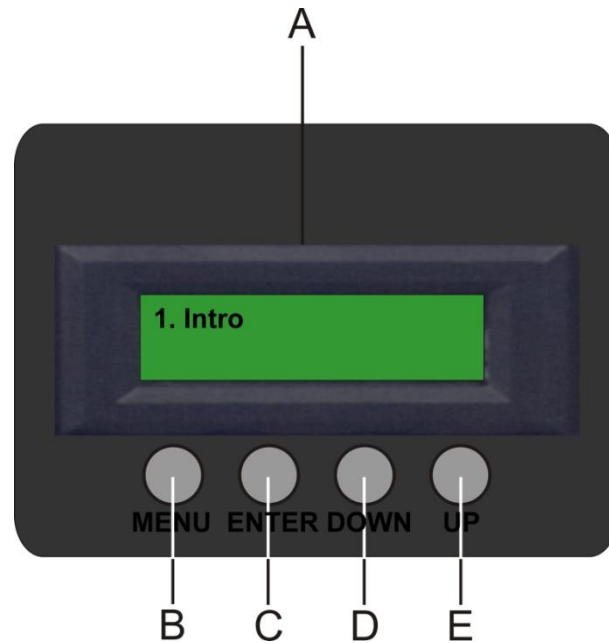

Fig. 5

- A. LCD Display
- B. MENU button
- C. ENTER Button
- D. Down Button
- E. Up Button

Control Mode

The fixtures are individually addressed on a data-link and connected to the controller. The fixtures respond to the DMX signal from the controller. (When you select the DMX address and save it, the controller will display the saved DMX address the next time.)

DMX Addressing

The control panel on the front side of the base allows you to assign the DMX fixture address, which is the first channel from which the Indigo will respond to the controller.

Please note when you use the controller, the unit has **12** channels.

When using multiple Indigo's, make sure you set the DMX addresses right.

Therefore, the DMX address of the first Indigo's should be **1(001)**; the DMX address of the second Indigo should be **1+12=13 (013)**; the DMX address of the third Indigo should be **13+12=25 (025)**, etc.

Please, be sure that you don't have any overlapping channels in order to control each Indigo correctly. If two or more Indigo's are addressed similarly, they will work similarly.

For address settings, please refer to the instructions under "Addressing".

Controlling:

After having addressed all Indigo fixtures, you may now start operating these via your lighting controller.

Note: After switching on, the Indigo will automatically detect whether DMX 512 data is received or not. If there is no data received at the DMX-input, the "**LED**" on the control panel will not flash.

The problem may be:

- The XLR cable from the controller is not connected with the input of the Indigo.
- The controller is switched off or defective, the cable or connector is defective, or the signal wires are swapped in the input connector.

Note: It's necessary to insert a XLR termination plug (with 120 Ohm) in the last fixture in order to ensure proper transmission on the DMX data link.

Menu Overview

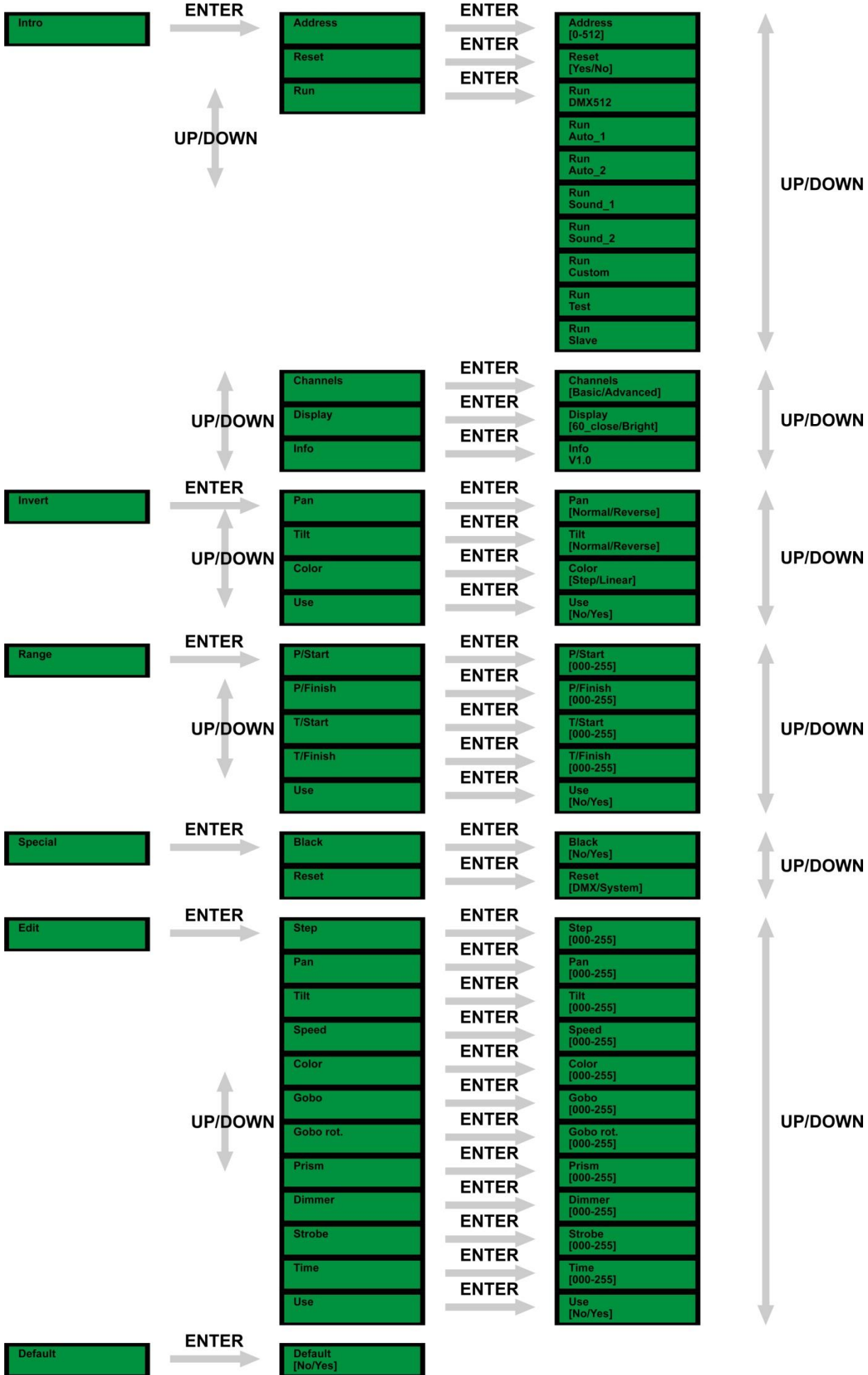

Main Menu Options

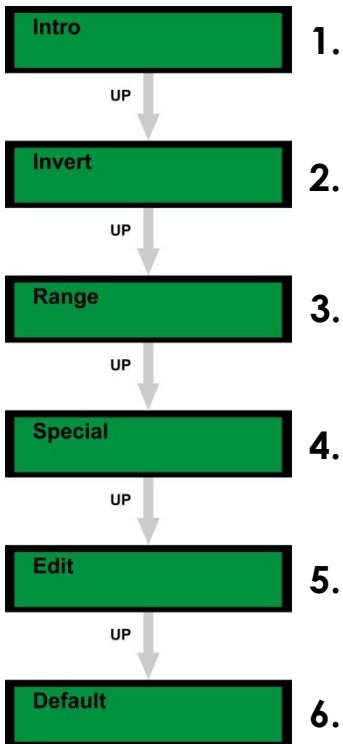

1. Intro

DMX Addressing

With this menu you can set the DMX address.



- 1) Press Menu, until the display shows: **Intro**
- 2) Press Enter and use the Up/Down buttons to go to the **Address** menu.
- 3) Press enter to open this menu. You can choose 512 different DMX addresses. Use the Up / Down buttons to select the required address from 000 - 512.
- 4) Once you have set the desired DMX address, press the enter button to store your DMX address.

Reset

With this menu you can reset the device.



- 1) Press Menu, until the display shows: **Intro**
- 2) Press Enter and use the Up/Down buttons to go to the **Reset** menu.
- 3) Press enter to open this menu. You can choose **Yes** or **No** mode. Use the Up / Down buttons to select one.
- 4) Once you have set Yes, the device will reset and it will take 15 seconds to reset.

DMX Active

With this menu you able to control the device by DMX.



- 1) Press Menu, until the display shows: **Intro**
- 2) Press Enter and use the Up/Down buttons to go to the **Run** menu.
- 3) Press enter to open this menu. Scroll through the menu until the display shows **DMX512**.
- 4) Once you have set DMX control, press the enter button to store your setting. The device will be DMX Controlled.

Built-in Programs Mode

With this menu you can select 5 different Programs when using the Indigo.

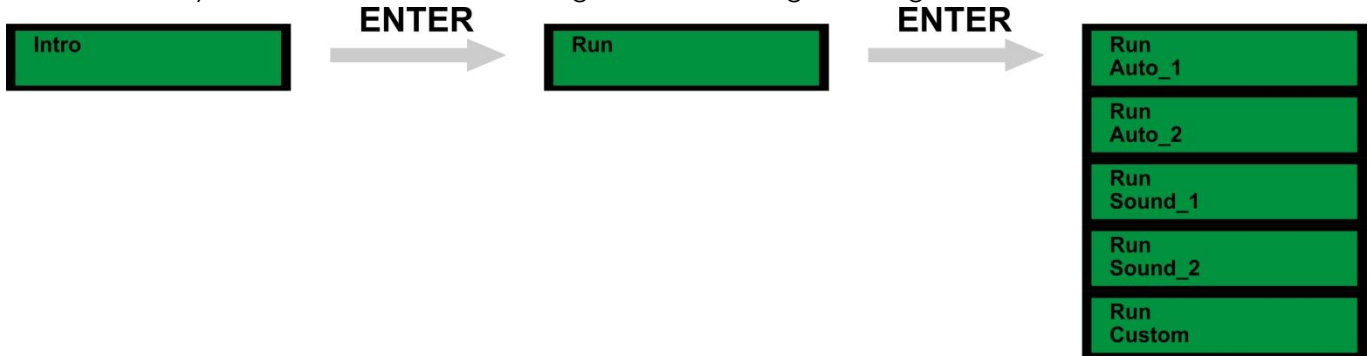

- 1) Press Menu, until the display shows: **Intro**
- 2) Press Enter and use the Up/Down buttons to go to the **Run** menu.
- 3) Press enter to open this menu. Scroll through the menu until the display shows **Auto_1**, **Auto_2**, **Sound_1**, **Sound_2** or **Custom**. You have 5 options to control the device as a stand-alone device.
- 4) Once you have chosen your desired mode, press the enter button to store your setting. The device will start the built-in program.

Built-in Programs (Auto_1 + Auto_2)

The device will play its built-in stand-alone programs.

Sound-controlled (Sound_1 + Sound_2)

The device will play its built-in stand-alone sound-controlled programs. The device is now sound-controlled and will react to the music.

Custom Mode



For a custom program to run, you have to enter some values first.
For more information, please see **Edit** menu.

Run Test

With this menu you are able to test the device.



- 1) Press Menu, until the display shows: **Intro**
- 2) Press Enter and use the Up/Down buttons to go to the **Run** menu.
- 3) Press enter to open this menu. Scroll through the menu until the display shows **TEST**.
- 4) When you press ENTER, the display will blink once and the device will start an internal test.

Slave Mode

With this menu you are able to set the device as a slave device.

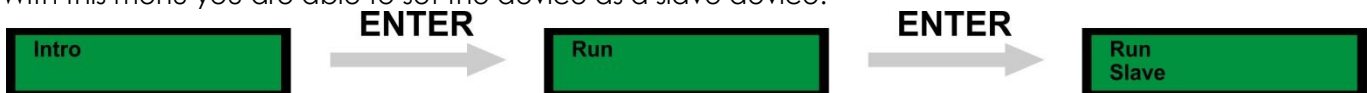

- 1) Press Menu, until the display shows: **Intro**
- 2) Press Enter and use the Up/Down buttons to go to the **Run** menu.
- 3) Press enter to open this menu. Scroll through the menu until the display shows **Slave**.
- 4) When you press ENTER, the display will blink once and the device will be in slave mode.

Channels Advanced/Basic Mode



- 1) Press Menu, until the display shows: **Intro**
- 2) Press Enter and use the Up/Down buttons to go to the **Channels** menu.
- 3) Press enter to open this menu. You can choose **Basic** (9CH) or **Advanced** (12CH) mode. Use the Up / Down buttons to select one.
- 4) Once you have set the desired mode, press the enter button to store your setting.

Display Mode



- 1) Press Menu, until the display shows: **Intro**
- 2) Press Enter and use the Up/Down buttons to go to the **Display** menu.
- 3) Press enter to open this menu. You can choose **60_close** or **Bright** mode. Use the Up / Down buttons to select one.
- 4) Once you have set the desired mode, press the enter button to store your setting.

Info version



- 1) Press Menu, until the display shows: **Intro**
- 2) Press Enter and use the Up/Down buttons to go to the **Info** menu.
- 3) Press enter to see your Indigo version number.

2. Invert

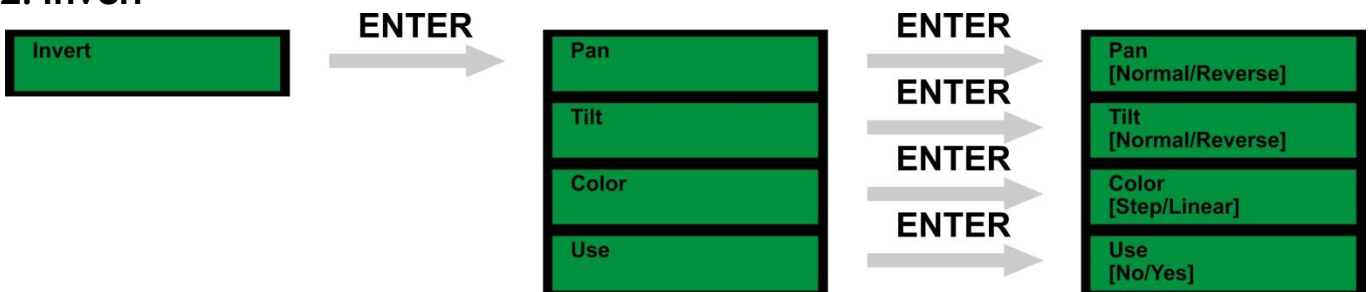

- 1) Press Menu, until the display shows: **Invert**
- 2) Press Enter and use the Up/Down buttons to scroll through the options: **Pan, Tilt, Color, Use**.
- 3) Press enter to open this menu. Use the Up / Down buttons to select one of the options.
- 4) Once you have set the desired mode, press the enter button to store your setting.

3. Range

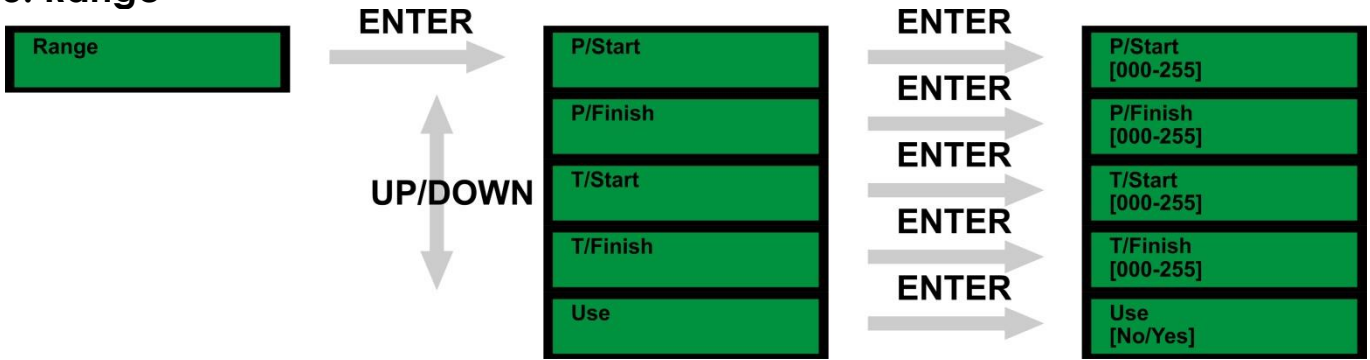

- 1) Press Menu, until the display shows: **Range**
- 2) Press Enter and use the Up/Down buttons to scroll through: **P/Start**, **P/Finish**, **T/Start**, **T/Finish**, **Use**.
- 3) Press enter to open this menu. Use the Up / Down buttons to set the desired value.
- 4) Once you have set the desired mode, press the enter button to store your setting.

4. Special



- 1) Press Menu, until the display shows: **Special**
- 2) Press Enter and use the Up/Down buttons to choose: **Black** or **Reset**.
- 3) Press enter to open this menu. Use the Up / Down buttons to set the desired setting.
- 4) Once you have set the desired mode, press the enter button to store your setting.

5. Edit

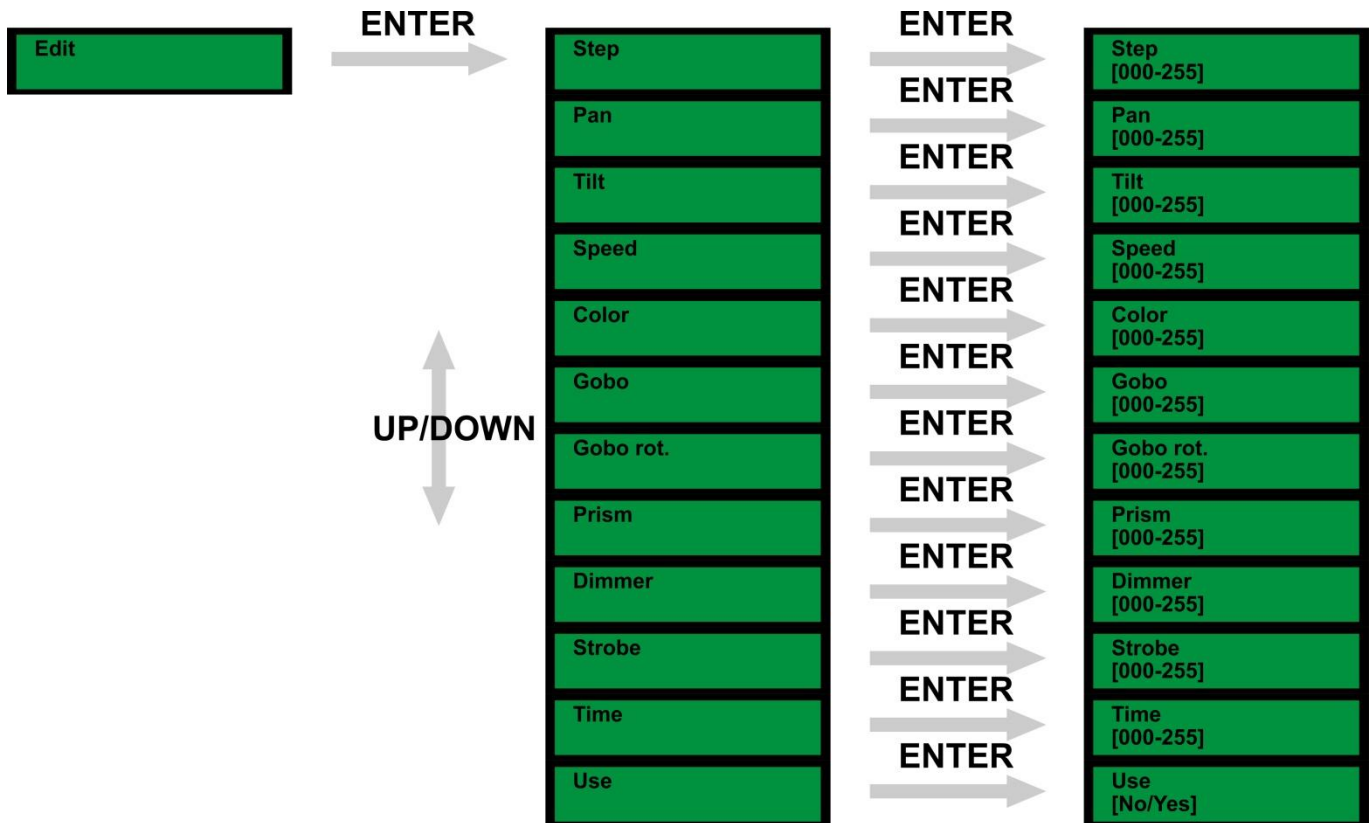

- 1) Press Menu, until the display shows: **Edit**
- 2) Press Enter and use the Up/Down buttons to scroll through the options: **Step, Pan, Tilt, Speed, Color, Gobo, Gobo Rot., Prism, Dimmer, Strobe, Time, Use.**
- 3) Press enter to open this menu. Use the Up / Down buttons to set the desired setting.
- 4) Once you have set the desired mode, press the enter button to store your setting.

Note: If you want to circulate the created steps, please set the last step as 0.

For example, when you have 3 steps, the setting should be:

Step 1	Time = 4	Use = Yes
Step 2	Time = 5	Use = Yes
Step 3	Time = 0	Use = Yes

6. Default



- 1) Press Menu, until the display shows: **Default**
- 2) Press Enter and use the Up/Down buttons to choose: **Yes** or **No**.
- 3) If you use Yes, the device will return to the factory default setting.

DMX Protocol 12 Channels (Advanced)

Channel 1 - Horizontal movement (Pan)

Push the slider up, in order to move head horizontally (PAN).

Gradual head adjustment from one end of the slider to the other (0-255, 128-center).

The head can be turned by 530° and stopped at any position you wish.

Channel 2 - Pan fine 16 bit

Channel 3 - Vertical movement (Tilt)

Push the slider, up in order to move head vertically (TILT).

Gradual head adjustment from one end of the slider to the other (0-255, 128-center).

The head can be turned by 270° and stopped at any position you wish.

Channel 4 - Tilt fine 16 bit

Channel 5 –PAN/TILT Speed

0-255	From Max Speed (0) to Min. Speed (255)
-------	--

Channel 6 – Colourwheel

Linear color change following the movement of the slider. Between 150 - 255, the color-wheel rotates continuously the so-called "Rainbow" effect.

0-14	Open / White
15-29	Red
30-44	Yellow
45-59	Green
60-74	Pink
75-89	Blue
90-104	Orange
105-119	Magenta
120-134	Light Blue
135-149	Light Green
150-255	Forwards rainbow effect from fast to slow

Channel 7 – Rotating Gobo-wheel + Gobo Shake

0-9	Open / White
10-19	Metal Gobo 1
20-29	Metal Gobo 2
30-39	Metal Gobo 3
40-49	Metal Gobo 4
50-59	Metal Gobo 5
60-69	Glass Gobo 6
70-79	Glass Gobo 7
80-99	Gobo Shake 7 from slow to fast
100-119	Gobo Shake 6 from slow to fast
120-139	Gobo Shake 5 from slow to fast
140-159	Gobo Shake 4 from slow to fast
160-179	Gobo Shake 3 from slow to fast
180-199	Gobo Shake 2 from slow to fast
200-219	Gobo Shake 1 from slow to fast
220-255	Forwards rainbow effect from slow to fast

Channel 8 – Rotation Gobo

0-2	No Rotation
3-6	Slowest rotation
7-128	Forwards gobo rotation from slow to fast
129-132	No Rotation
133-136	Backwards Slowest rotation
137-255	Backwards gobo rotation from slow to fast

Channel 9 – Prism rotating control

0-127	No Function
128-255	3-facet Prism Effect

Channel 10 – Dimmer intensity

0-255	From black to brightest
-------	-------------------------

Channel 11 – Shutter / Strobe (Dimmer must be open)

0-31	Shutter closed / Blackout
32-63	Shutter open
64-95	Strobe effect, from slow to fast (0-10 flashes/sec.)
96-127	Shutter open
128-159	Pulse-effect, in sequences from slow to fast
160-191	Shutter open
192-223	Random strobe effect, from slow to fast
224-255	Shutter open

Channel 12 – Channel Functions

 **When you have entered one of the functions between 20-39, you must first disable this function, before the device will operate normally.** 

0-19	No Function
20-39	Blackout during Pan/Tilt movement
40-59	Disabled blackout during Pan/Tilt movement
60-79	Auto 1 (activated after 3 seconds)
80-99	Auto 2 (activated after 3 seconds)
100-119	Sound 1 (activated after 3 seconds)
120-139	Sound 2 (activated after 3 seconds)
140-159	Custom
160-179	Test (activated after 3 seconds)
180-199	No Function
200-219	Reset (activated after 3 seconds)
220-255	No Function

DMX Protocol 9 Channels (Basic)

Channel 1 - Horizontal movement (Pan)

Push the slider up, in order to move head horizontally (PAN).

Gradual head adjustment from one end of the slider to the other (0-255, 128-center).

The head can be turned by 530° and stopped at any position you wish.

Channel 3 – Colourwheel

Linear color change following the movement of the slider. Between 150 - 255, the color-wheel rotates continuously the so-called "Rainbow" effect.

0-14	Open / White
15-29	Red
30-44	Yellow
45-59	Green
60-74	Pink
75-89	Blue
90-104	Orange
105-119	Magenta
120-134	Light Blue
135-149	Light Green
150-255	Forwards rainbow effect from fast to slow

Channel 4 – Rotating Gobo-wheel + Gobo Shake

0-9	Open / White
10-19	Metal Gobo 1
20-29	Metal Gobo 2
30-39	Metal Gobo 3
40-49	Metal Gobo 4
50-59	Metal Gobo 5
60-69	Glass Gobo 6
70-79	Glass Gobo 7
80-99	Gobo Shake 7 from slow to fast
100-119	Gobo Shake 6 from slow to fast
120-139	Gobo Shake 5 from slow to fast
140-159	Gobo Shake 4 from slow to fast
160-179	Gobo Shake 3 from slow to fast
180-199	Gobo Shake 2 from slow to fast
200-219	Gobo Shake 1 from slow to fast
220-255	Forwards rainbow effect from slow to fast

Channel 5 – Rotation Gobo

0-2	No Rotation
3-6	Slowest rotation
7-128	Forwards gobo rotation from slow to fast
129-132	No Rotation
133-136	Backwards Slowest rotation
137-255	Backwards gobo rotation from slow to fast

Channel 6 – Prism rotating control

0-127	No Function
128-255	3-facet Prism Effect

Channel 7 – Dimmer intensity

0-255	From black to brightest
-------	-------------------------

Channel 8 – Shutter / Strobe (Dimmer must be open)

0-31	Shutter closed / Blackout
32-63	Shutter open
64-95	Strobe effect, from slow to fast (0-10 flashes/sec.)
96-127	Shutter open
128-159	Pulse-effect, in sequences from slow to fast
160-191	Shutter open
192-223	Random strobe effect, from slow to fast
224-255	Shutter open

Channel 9 – Channel Functions

 **When you have entered one of the functions between 20-39, you must first disable this function, before the device will operate normally.** 

0-19	No Function
20-39	Blackout during Pan/Tilt movement
40-59	Disabled blackout during Pan/Tilt movement
60-79	Auto 1 (activated after 3 seconds)
80-99	Auto 2 (activated after 3 seconds)
100-119	Sound 1 (activated after 3 seconds)
120-139	Sound 2 (activated after 3 seconds)
140-159	Custom
160-179	Test (activated after 3 seconds)
180-199	No Function
200-219	Reset (activated after 3 seconds)
220-255	No Function

Channel settings

41379 Indigo 150-LED Fixture-settings												
Channel	1	2	3	4	5	6	7	8	9	10	11	12
Function	Pan	Pan-Fine	Tilt	Tilt-Fine	Pan/Tilt Speed	Color	Rotating Gobowheel	Gobo Rotation	Prism Rotation	Dimmer	Shutter Macro	Control
255 128 0	255 540° 0°	255 0	255 270° 0°	255 0	255 Slow 0 Fast	150-255 Rainbow-rot Slow to fast 135-149 120-134 105-119 90-104 75-89 60-74 45-59 30-44 16-29 0-15	220-255 200-219 180-199 160-179 140-159 120-139 100-119 80-99 70-79 60-69 50-59 40-49 30-39 20-29 10-19 0-9	255 Fast 137 Slow 136 Slowest 133 Slowest 129 No Function 128 7 Fast 6 3 Slowest 2 0 No Rotation	255 Prism Effect 128 127 0 No Function	255 0	255 Shutter Open 224 223 Fast Random Strobe 192 Slow 191 Fast Shutter Open 160 159 Fast Pulse Effect 128 Slow 127 Shutter Open 96 95 Fast Strobe 64 Slow 63 Shutter Open 32 31 0 Shutter Closed	255 No Function 220 219 Reset activated after 3 sec 200 199 No Function 180 179 Test activated after 3 sec 160 159 Custom activated after 3 sec 140 139 Sound 2 activated after 3 sec 120 119 Sound 1 activated after 3 sec 100 99 Auto 2 activated after 3 sec 80 79 Auto 1 activated after 3 sec 60 59 Pan/Tilt deactivated after 3 sec 40 39 Pan/Tilt activated after 3 sec 20 19 No Function 0

Beam Angle

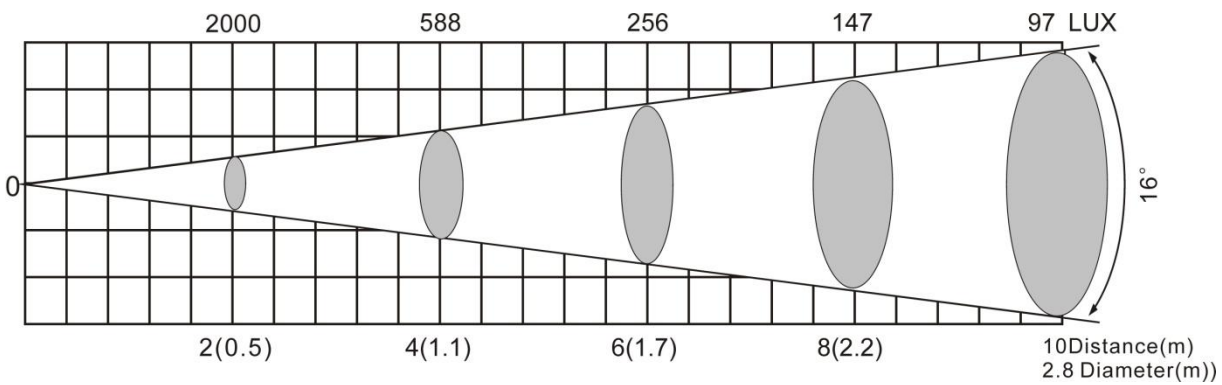

Fig. 6

Maintenance

The operator has to make sure that safety-relating and machine-technical installations are to be inspected by an expert after every year in the course of an acceptance test.

The operator has to make sure that safety-relating and machine-technical installations are to be inspected by a skilled person once a year.

The following points have to be considered during the inspection:

1. All screws used for installing the device or parts of the device have to be tightly connected and must not be corroded.
2. There may not be any deformations on housings, fixations and installation spots.
3. Mechanically moving parts like axles, eyes and others may not show any traces of wearing.
4. The electric power supply cables must not show any damages or material fatigue.

The Showtec Indigo 150 LED requires almost no maintenance. However, you should keep the unit clean. Otherwise, the fixture's light-output will be significantly reduced. Disconnect the mains power supply, and then wipe the cover with a damp cloth. Do not immerse in liquid. Wipe lens clean with glass cleaner and a soft cloth. Do not use alcohol or solvents.

The front lens will require weekly cleaning, as smoke-fluid tends to build up residues, reducing the light-output very quickly.

The cooling-fans, colour-wheel, the gobowheel, the gobos and the internal lenses should be cleaned

monthly with a soft brush.

Please clean internal components once a year with a light brush and vacuum cleaner.

Keep connections clean. Disconnect electric power, and then wipe the DMX and audio connections with a damp cloth. Make sure connections are thoroughly dry before linking equipment or supplying electric power.

Replacing a Fuse

Power surges, short-circuit or inappropriate electrical power supply may cause a fuse to burn out. If the fuse burns out, the product will not function whatsoever. If this happens, follow the directions below to do so.

1. Unplug the unit from electric power source.
2. Insert a flat-head screwdriver into a slot in the fuse cover. Gently pry up the fuse cover. The fuse will come out.
3. Remove the used fuse. If brown or unclear, it is burned out.
4. Insert the replacement fuse into the holder where the old fuse was. Reinsert the fuse cover. Be sure to use a fuse of the same type and specification. See the product specification label for details.

Replacing a Gobo

Gobo-wheel with rotating gobo's

1. Disconnect mains power supply and set the switch to OFF.
2. Make sure that the gobo you want to insert has the same size. For the right size, see below.

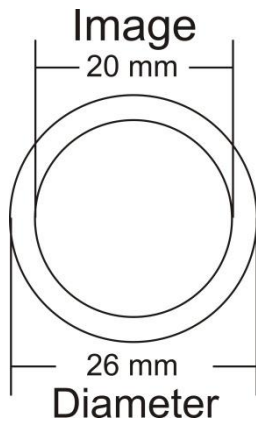
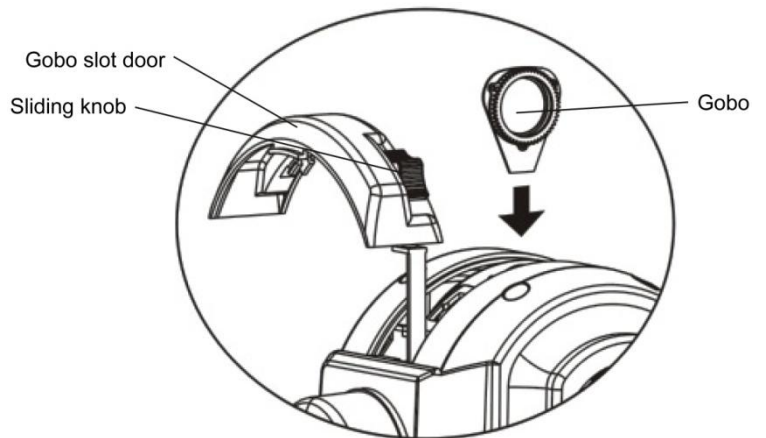

Fig. 7



3. Unlock the 2 goboslots on top of the housing. Lift the small maintenance cap.
4. Turn the gobo wheel, with the gobo you want to remove, to the upside.
4. Gently lift up the gobo holder 10° and then gently pull out the gobo from its position.
5. Very carefully take the gobo out of the gobo holder with a pair of pliers.
6. Place the new gobo in the gobo holder. Carefully put the pinchcock back, gently press the pinchcock a little bit together. Possibly use a pair of pliers to press the pinchcock a little bit together.
7. Put the gobo holder back under the pressing snap and push it back.
8. Replace the maintenance cap and fasten all screws.

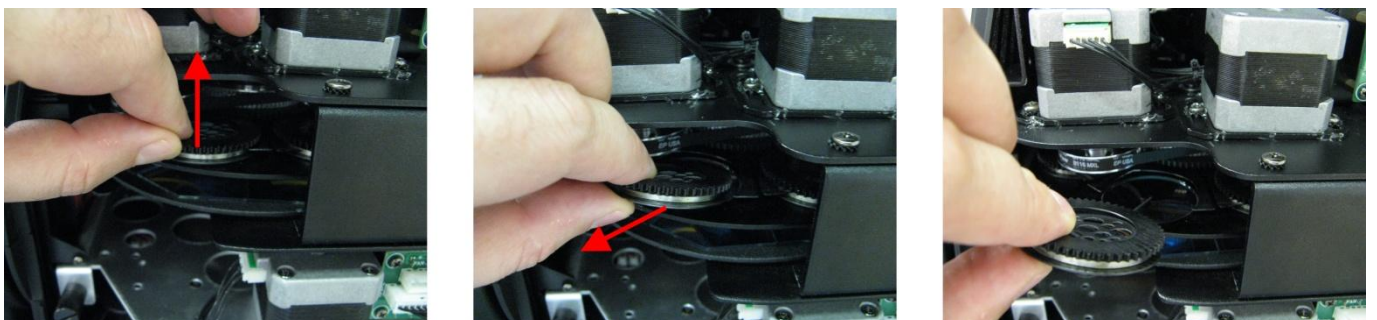
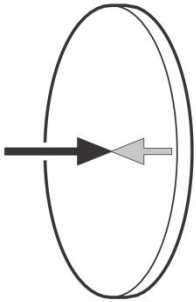

Fig. 8

Glass Gobo Orientation

Coated glass gobos are inserted with the coating against the rim of the holder (away from the spring). Textured gobos are inserted with the smooth side against the spring. This provides the best results when combining rotating gobos.

Coated side



When an object is held up to the coated side there is no space between the object and its reflection. The back edge of the gobo cannot be seen when looking through the coated side.

Uncoated side

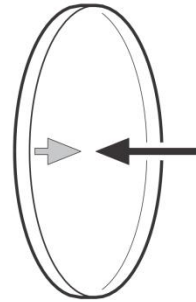

When an object is held up to the uncoated side there is a space between the object and its reflection. The back edge of the gobo can be seen when looking through the uncoated side.

Rotating Gobo-wheel

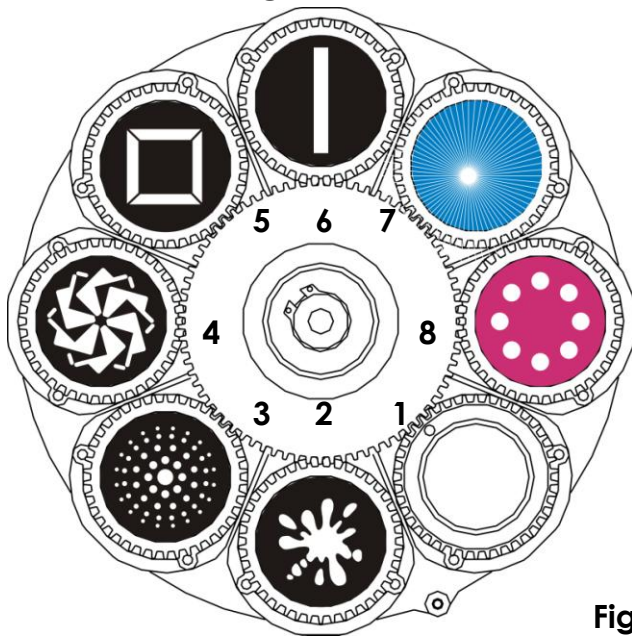

Fig. 9

Color-wheel

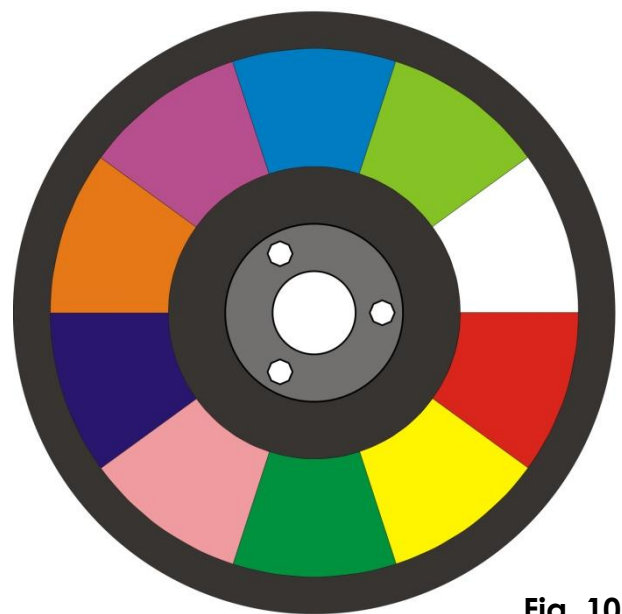

Fig. 10

Troubleshooting

No Light, No Movement - All Products

This troubleshooting guide is meant to help solve simple problems. If a problem occurs, carry out the steps below in sequence until a solution is found. Once the unit operates properly, do not carry out following steps.

If the light effect does not operate properly, refer servicing to a technician.

Response: Suspect three potential problem areas: the power supply, the lamp, the fuse.

1. Power supply. Check that the unit is plugged into an appropriate power supply.
2. The LEDs. Return the Indigo 150 LED to your Showtec dealer.
3. The fuse. Replace the fuse. See page 23 for replacing the fuse.

No Response to DMX

Response: Suspect the DMX cable or connectors, a controller malfunction, a light effect DMX card malfunction.

1. Check the DMX cable: Unplug the unit; change the DMX cable; then reconnect to electrical power. Try your DMX control again.
2. Determine whether the controller or light effect is at fault. Does the controller operate properly with other DMX products? If not, take the controller in for repair. If so, take the DMX cable and the light effect to a qualified technician.

Problem	Probable cause(s)	Remedy
One or more fixtures are completely dead.	No power to the fixture	· Check that power is switched on and cables are plugged in.
	Primary fuse blown.	· Replace fuse.
Fixtures reset correctly, but all respond erratically or not at all to the controller.	The controller is not connected.	· Connect controller.
	3-pin XLR Out of the controller does not match XLR Out of the first fixture on the link (i.e. signal is reversed).	· Install a phase reversing cable between the controller and the first fixture on the link.
Fixtures reset correctly, but some respond erratically or not at all to the controller.	Poor data quality	· Check data quality. If much lower than 100 percent, the problem may be a bad data link connection, poor quality or broken cables, missing termination plug, or a defective fixture disturbing the link.
	Bad data link connection	· Inspect connections and cables. Correct poor connections. Repair or replace damaged cables.
	Data link not terminated with 120 Ohm termination plug.	· Insert termination plug in output jack of the last fixture on the link.
	Incorrect addressing of the fixtures.	· Check address setting.
	One of the fixtures is defective and disturbs data transmission on the link.	· Bypass one fixture at a time until normal operation is regained: unplug both connectors and connect them directly together. · Have the defective fixture serviced by a qualified technician.
	3-pin XLR Out on the fixtures does not match (pins 2 and 3 reversed).	· Install a phase-reversing cable between the fixtures or swap pin 2 and 3 in the fixture, that behaves erratically.
Shutter closes suddenly	The color wheel, gobo wheel, or a gobo has lost its index position and the fixture is resetting the effect.	· Contact a technician for servicing if the problem persists.
No light	The power supply settings do not match local AC voltage and frequency.	· Disconnect fixture. Check settings and correct if necessary.
	LEDs damaged	· Disconnect fixture and return to your dealer.
Lamp cuts out intermittently.	Fixture is too hot.	· Allow fixture to cool. · Clean fan. · Make sure air vents at control panel and front lens are not blocked. · Turn up the air conditioning.
	The power supply settings do not match local AC voltage and frequency.	· Disconnect fixture. Check settings and correct if necessary.

Product Specification

Model: Showtec Indigo 150 LED

Voltage: 240V-50Hz (CE)

Power Consumption: 20W

Fuse: T1,5A / 250V

Dimensions: 210x245x370mm (LxWxH)

Weight: 6,3 kg

Operation and Programming

Signal pin OUT: pin 1 earth, pin 2 (-), pin 3 (+)

Set Up and Addressing: LED control panel

DMX Channels: 9 or 12

Signal input 3-pin XLR male

Signal output 3-pin XLR female

Electro-mechanical effects

Automatic Pan/Tilt correction

Music Control

Automatic Pan/Tilt correction

Gobowheel with 7 rotating gobos and open

Gobo Shake Function

Colourwheel with 9 vivid colours and white

Manual Focus

Cooling system: Low Noise Fan

Beam Angle: 16 ° degrees

Gobo size: 26 mm

Image size: 20 mm

Shutter: 0-10Hz

Dimmer: 0-100% Mechanical dimmer

Pan 0° -- 530°

Tilt 0° -- 270°

Movement resolution: selectable 8/16 bit

Control: DMX-512, Master/Slave, Sound

Basic (9CH) or Advanced (12CH) operating modes

Bright LCD display

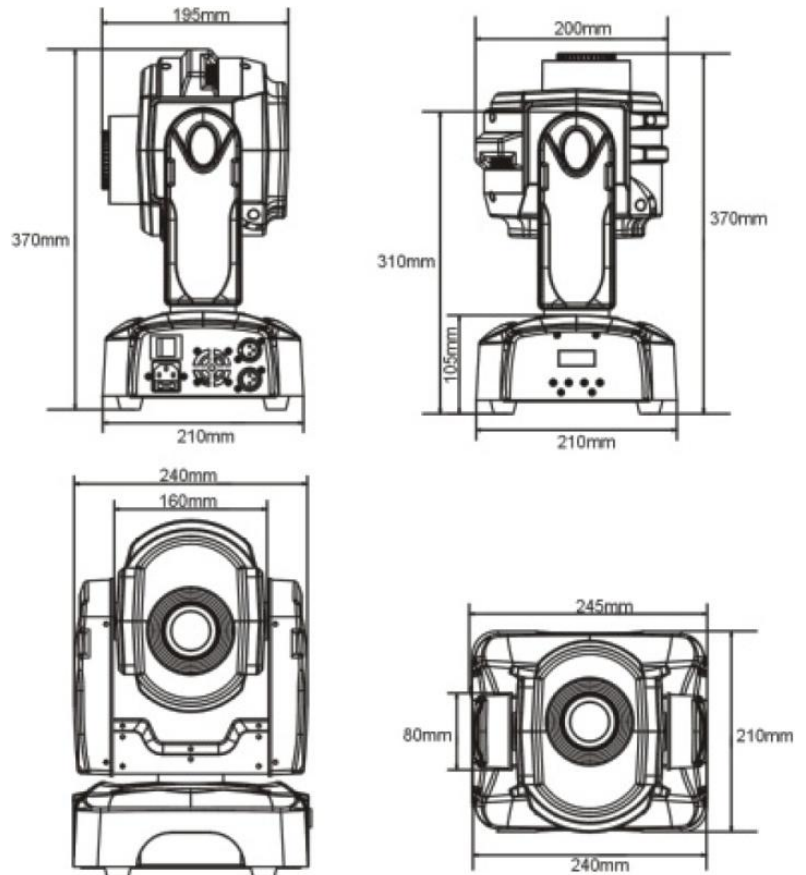

Gobos

Colourwheel: heat-resistant and intensify glass; dichroic glass coating

Max. ambient temperature t_a : 40°C; Max. housing temperature t_B : 80°C

Cooling: 1 fan in the projector

Motor: high quality stepping-motor controlled by microprocessors

Minimum distance:

Minimum distance from flammable surfaces: 0.5m

Minimum distance to lighted object: 1.3m

Design and product specifications are subject to change without prior notice.



Website: www.Showtec.info

Email: service@highlite.nl



© 2009 Showtec.